

9 December 2020

Your Reference:
 Our Reference: DA200174

Burnett Country Certifiers
 12/58 Newton Street
 MONTO QLD 4630

Dear Sir

CONCURRENCE AGENCY RESPONSE
1 STUART STREET, MONTO
 (Given under section 56(4) of the *Planning Act 2016*)

Thank you for your concurrence agency referral for the following premises which was properly referred on 9 December 2020. The North Burnett Regional Council has assessed the referral against the relevant matters of its jurisdiction and has made a decision as follows:

Applicant details

Applicant name: Burnett Country Certifiers
 Applicant contact details: 12/58 Newton Street, Monto
 Email: monto@burnettcc.com.au
 Phone: 4166 3108

Location details

Street address: 1 Stuart Street, Monto
 Real property description: Lot 18 on RP73704
 Local government area: North Burnett Regional Council

Application details

Application No: DA200174
 Proposed development: Development Permit for Building Works

Aspects of development and type of approval being sought

Nature of Development	Approval Type	Brief Description of Proposal
Amenity and Aesthetics	Development Permit	Class 10a – Shipping Container

Referral triggers

The development application was referred to the Council under the following provisions of the *Planning Regulation 2017*

Referral trigger

Schedule 9 – Building work assessable against the *Building Act* Part 3 Division 2 Table 1 Particular class 1 and 10 building and structures involving possible amenity and aesthetic impact.

Decision

Decision Details:

The North Burnett Regional Council advises the assessment manager that -
The development approval must be subject to stated development conditions set out in Attachment 1.

Conditions

This approval is subject to the conditions in Attachment 1.

The North Burnett Regional Council advises the assessment manager that the conditions must be attached to any development approval for the application in accordance with section 56 of the *Planning Act 2016* and that under section 62(b) of the *Planning Act 2016*. The assessment manager must attach this response to any approval for the development.

Reasons for decision to impose conditions

Under section 56 (7) (c) of the *Planning Act 2016*, the North Burnett Regional Council is required to set out reasons for the decision to impose conditions. These reasons are set out in Attachment 2.

Approved Plans and Specifications

Document Number Reference	Title (prepared by)	Date
SP4100/20	Site Plan. Queensland Glove	3/12/20
E4100/20	Elevations Shipping Containers	3/12/20
TD4100/20	Tie Down Shipping Containers	3/12/20

Giving of the Notice

Under section 56(4) of the *Planning Act 2016*, this notice of referral agency response has been issued (where applicable) to the applicant and the assessment manager of the application.

Should you require any further assistance in process, please contact Council's Development Services Department on 1300 696 272.

Yours faithfully



Jeff Miles

Planning and Environment Manager

Enc: Schedule 1-conditions to be imposed
Schedule 2-reasons for decision to impose conditions
Schedule 3-appeal rights
Schedule 4-plans

Schedule 1 – Conditions to be imposed by Concurrence Agency

No.	Conditions
General	
1.	Unless otherwise stated in a particular condition, all conditions must be completed prior to the completion of building works, or issue of a final certificate, whichever is the sooner, unless otherwise agreed to in writing by the Concurrence Agency.
Design and Siting	
2.	The approved shipping container must be sited generally in accordance with the approved plans with all setbacks measures from the outmost projection of the structure.
3.	The floor area of the approved shipping container must not exceed 15m ² .
4.	The overall height of the approved shipping container must not exceed 3 metres measured from natural ground level. Any earthworks required for the development must be undertaken in such a way as to ensure that the height of the building complies with this condition.
5.	Utilise colours in the development that are sympathetic to the surrounding environment and avoid excessive brightness, contrast, colour intensity and reflectivity. In this regard, materials/colours on the roof and wall of the structures must not reflect glare into the habitable rooms of any dwelling on surrounding allotments.
Use	
6.	The approved shipping container is to be used for private/domestic purposes only. The approved structure must not be used as a separate domicile/dwelling or used for any industrial/business use unless valid development approvals are granted for such uses. To this end, the use of any of the approved building/s associated with this approval must be ancillary and incidental to the predominant use of the site for a Dwelling Unit
7.	Complete all external wall and roof finishes so as to provide a surface that is free of flaking paint, stains or rust. Wall finishes are to be renewed or replaced so as to match the colour and finish of surrounding wall areas of the building or structure.

Schedule 1b – Advice Notes

A.	This Concurrence Agency Response does not represent a development approval for Building Works under the <i>Building Act 1975</i> .
B.	All building works the subject of this notice can only proceed once a development permit for building works is issued by a Building Certifier.
C.	Please note this amenity and aesthetics assessment pertains to the approval of a class 10 building only (defined as including a private garage, carport, shed or like). It is recommended that clarification from a Building Certifier be sought to ensure that an appropriate building classification is applied to align with the building size, purpose, use and intent of operations within the building.

Schedule 2 – Reasons for decision to impose conditions

The reason for this decision are:

- To ensure the development is carried out generally in accordance with the plans of development submitted with the application.
- The Amenity and Aesthetics policy adopted by North Burnett Regional Council on the 4 November 2016 states that matters for consideration are to be the architectural style, building form, construction materials and physical condition of the proposed structure complements the existing locality and surrounding pattern of development.

Schedule 3 – Appeal Rights Planning Act 2016

CHAPTER 6, PART 1 APPEAL RIGHTS

229 Appeals to tribunal or P&E Court

- (1) Schedule 1 states—
- (a) matters that may be appealed to—
 - (i) either a tribunal or the P&E Court; or
 - (ii) only a tribunal; or
 - (iii) only the P&E Court; and
 - (b) the person—
 - (i) who may appeal a matter (the appellant); and
 - (ii) who is a respondent in an appeal of the matter; and
 - (iii) who is a co-respondent in an appeal of the matter; and
 - (iv) who may elect to be a co-respondent in an appeal of the matter.
- (2) An appellant may start an appeal within the appeal period.
- (3) The **appeal period** is—
- (a) for an appeal by a building advisory agency—10 business days after a decision notice for the decision is given to the agency; or
 - (b) for an appeal against a deemed refusal—at any time after the deemed refusal happens; or
 - (c) for an appeal against a decision of the Minister, under chapter 7, part 4, to register premises or to renew the registration of premises—20 business days after a notice is published under section 269(3)(a) or (4); or
 - (d) for an appeal against an infrastructure charges notice—20 business days after the infrastructure charges notice is given to the person; or
 - (e) for an appeal about a deemed approval of a development application for which a decision notice has not been given—30 business days after the applicant gives the deemed approval notice to the assessment manager; or
 - (f) for any other appeal—20 business days after a notice of the decision for the matter, including an enforcement notice, is given to the person.
- Note — See the P&E Court Act for the court's power to extend the appeal period.*
- (4) Each respondent and co-respondent for an appeal may be heard in the appeal.
- (5) If an appeal is only about a referral agency's response, the assessment manager may apply to the tribunal or P&E Court to withdraw from the appeal.
- (6) To remove any doubt, it is declared that an appeal against an infrastructure charges notice must not be about—
- (a) the adopted charge itself; or
 - (b) for a decision about an offset or refund—
 - (i) the establishment cost of trunk infrastructure identified in a LGIP; or
 - (ii) the cost of infrastructure decided using the method included in the local government's charges resolution.

230 Notice of appeal

- (1) An appellant starts an appeal by lodging, with the registrar of the tribunal or P&E Court, a notice of appeal that—
- (a) is in the approved form; and
 - (b) succinctly states the grounds of the appeal.
- (2) The notice of appeal must be accompanied by the required fee.
- (3) The appellant or, for an appeal to a tribunal, the registrar must, within the service period, give a copy of the notice of appeal to—
- (a) the respondent for the appeal; and
 - (b) each co-respondent for the appeal; and
 - (c) for an appeal about a development application under schedule 1, table 1, item 1—each principal submitter for the development application; and
 - (d) for an appeal about a change application under schedule 1, table 1, item 2—each principal submitter for the change application; and
 - (e) each person who may elect to become a co-respondent for the appeal, other than an eligible submitter who is not a principal submitter in an appeal under paragraph (c) or (d); and
 - (f) for an appeal to the P&E Court—the chief executive; and
 - (g) for an appeal to a tribunal under another Act—any other person who the registrar considers appropriate.
- (4) The **service period** is—
- (a) if a submitter or advice agency started the appeal in the P&E Court—2 business days after the appeal is started; or
 - (b) otherwise—10 business days after the appeal is started.
- (5) A notice of appeal given to a person who may elect to be a co-respondent must state the effect of subsection (6).
- (6) A person elects to be a co-respondent by filing a notice of election, in the approved form, within 10 business days after the notice of appeal is given to the person.

SCHEDULE 1 APPEALS

1 Appeal rights and parties to appeals

- (1) Table 1 states the matters that may be appealed to—
 - (a) the P&E court; or
 - (b) a tribunal.
- (2) However, table 1 applies to a tribunal only if the matter involves—
 - (a) the refusal, or deemed refusal of a development application, for—
 - (i) a material change of use for a classified building; or
 - (ii) operational work associated with building work, a retaining wall, or a tennis court; or
 - (b) a provision of a development approval for—
 - (i) a material change of use for a classified building; or
 - (ii) operational work associated with building work, a retaining wall, or a tennis court; or
 - (c) if a development permit was applied for—the decision to give a preliminary approval for—
 - (i) a material change of use for a classified building; or
 - (ii) operational work associated with building work, a retaining wall, or a tennis court; or
 - (d) a development condition if—
 - (i) the development approval is only for a material change of use that involves the use of a building classified under the Building Code as a class 2 building; and
 - (ii) the building is, or is proposed to be, not more than 3 storeys; and
 - (iii) the proposed development is for not more than 60 sole-occupancy units; or
 - (e) a decision for, or a deemed refusal of, an extension application for a development approval that is only for a material change of use of a classified building; or
 - (f) a decision for, or a deemed refusal of, a change application for a development approval that is only for a material change of use of a classified building; or
 - (g) a matter under this Act, to the extent the matter relates to—
 - (i) the Building Act, other than a matter under that Act that may or must be decided by the Queensland Building and Construction Commission; or
 - (ii) the Plumbing and Drainage Act, part 4 or 5; or
 - (h) a decision to give an enforcement notice in relation to a matter under paragraphs (a) to (g); or
 - (i) a decision to give an infrastructure charges notice; or
 - (j) the refusal, or deemed refusal, of a conversion application; or
 - (k) a matter that, under another Act, may be appealed to the tribunal; or
 - (l) a matter prescribed by regulation.
- (3) Also, table 1 does not apply to a tribunal if the matter involves—
 - (a) for a matter in subsection (2)(a) to (d)—
 - (i) a development approval for which the development application required impact assessment; and
 - (ii) a development approval in relation to which the assessment manager received a properly made submission for the development application; or
 - (b) a provision of a development approval about the identification or inclusion, under a variation approval, of a matter for the development.
- (4) Table 2 states the matters that may be appealed only to the P&E Court.
- (5) Table 3 states the matters that may be appealed only to the tribunal.
- (6) In each table—
 - (a) column 1 states the appellant in the appeal; and
 - (b) column 2 states the respondent in the appeal; and
 - (c) column 3 states the co-respondent (if any) in the appeal; and
 - (d) column 4 states the co-respondents by election (if any) in the appeal.
- (7) If the chief executive receives a notice of appeal under section 230(3)(f), the chief executive may elect to be a co-respondent in the appeal.
- (8) In this section—

storey see the Building Code, part A1.1.

Extract of Schedule 1 of the Planning Act 2016

Table 1			
Appeals to the P&E Court and, for certain matters, to a tribunal			
<p>1. Development applications An appeal may be made against—</p> <p>(a) the refusal of all or part of the development application; or</p> <p>(b) the deemed refusal of the development application; or</p> <p>(c) a provision of the development approval; or</p> <p>(d) if a development permit was applied for—the decision to give a preliminary approval.</p>			
Column 1 Appellant	Column 2 Respondent	Column 3 Co-respondent (if any)	Column 4 Co-respondent by election (if any)
The applicant	The assessment manager	If the appeal is about a concurrence agency's referral response—the concurrence agency	<p>1 A concurrence agency that is not a co-respondent</p> <p>2 If a chosen assessment manager is the respondent—the prescribed assessment manager</p> <p>3 Any eligible advice agency for the application</p> <p>4 Any eligible submitter for the application</p>

Table 3			
Appeals to a tribunal only			
<p>1. Building advisory agency appeals An appeal may be made against giving a development approval for building work to the extent the building work required code assessment against the building assessment provisions.</p>			
Column 1 Appellant	Column 2 Respondent	Column 3 Co-respondent (if any)	Column 4 Co-respondent by election (if any)
A building advisory agency for the development application related to the approval	The assessment manager	The applicant	<p>1 A concurrence agency for the development application related to the approval.</p> <p>2 A private certifier for the development application related to the approval</p>
<p>2. Inspection of building work An appeal may be made against a decision of a building certifier or referral agency about the inspection of building work that is the subject of a building development approval under the Building Act.</p>			
Column 1 Appellant	Column 2 Respondent	Column 3 Co-respondent (if any)	Column 4 Co-respondent by election (if any)
The applicant for the development approval	The person who made the decision.	—	—
<p>3. Certain decisions under the Building Act and the Plumbing and Drainage Act An appeal may be made against—</p> <p>(a) a decision under the Building Act, other than a decision made by the Queensland Building and Construction Commission, if an information notice about the decision was given or required to be given under that Act; or</p> <p>(b) a decision under the Plumbing and Drainage Act, part 4 or 5, if an information notice about the decision was given or required to be given under that Act.</p>			
Column 1 Appellant	Column 2 Respondent	Column 3 Co-respondent (if any)	Column 4 Co-respondent by election (if any)
A person who received, or was entitled to receive, an information notice about the decision.	The person who made the decision	—	—
<p>4. Local government failure to decide application under the Building Act An appeal may be made against a local government's failure to decide an application under the Building Act within the period required under that Act.</p>			

Attachment 4 - Approved Plans

Intentionally Left Blank

Please refer to the following pages for approved plans.



24°52'10"S 151°16'59"E

24°52'10"S 151°16'59"E



APPROVED PLANS
 These plans are associated to the
 Decision Notice for application number
DA200174

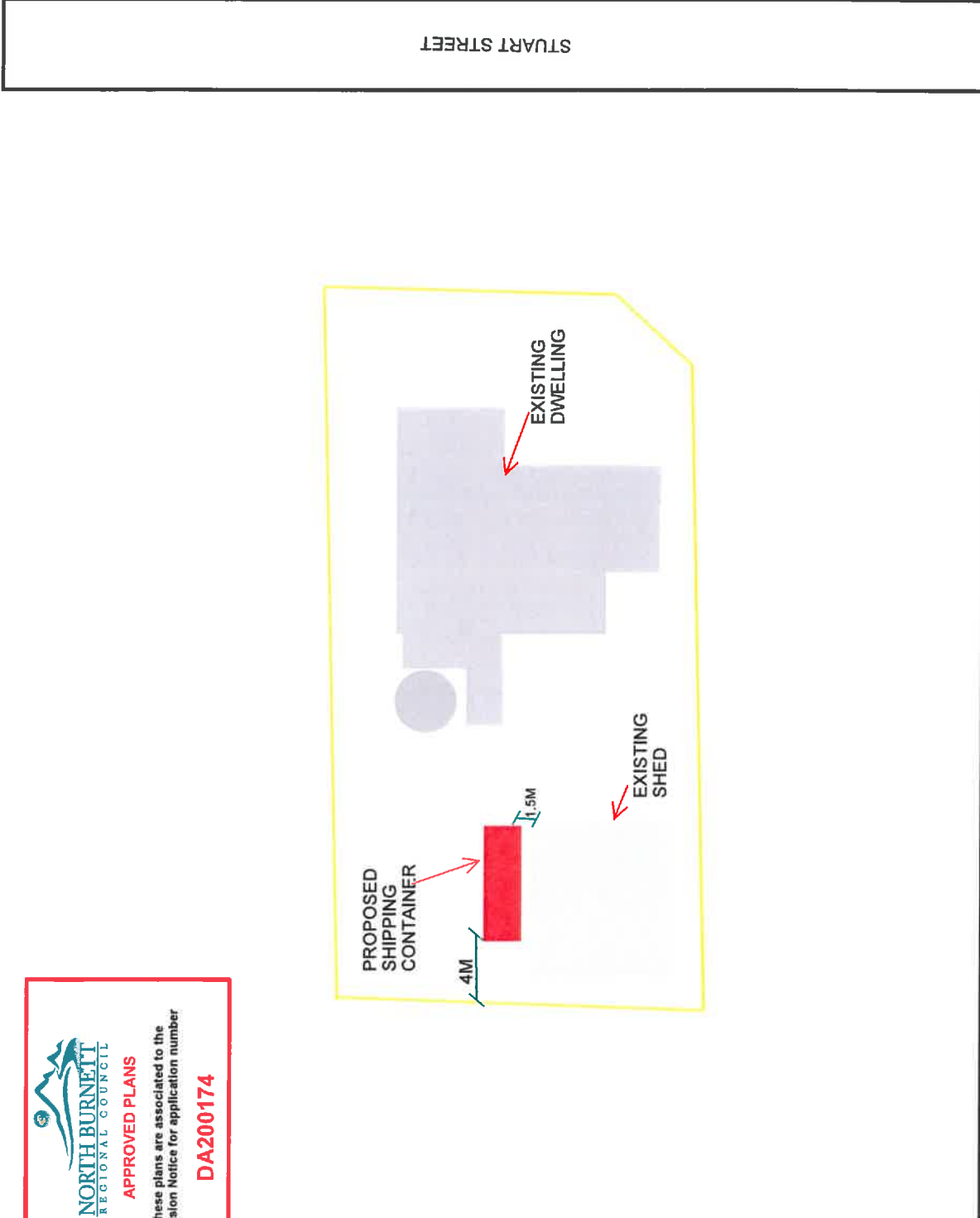

DRAWING TITLE SITE PLAN
 DRAWING NO. SP4100/20
 DATE 3/12/20
 ADDRESS 1 Stuart Street, MONTO
 LOT 18/RP73704
 OWNER R Gaine

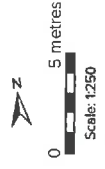

Printed at: A3
 Print date: 23/11/2020
 Datum: Geocentric Datum of Australia 1994
 Projection: Web Mercator EPSG 102100
 For more information, visit <https://ddp.qld.gov.au/help-info/contact-us.html>

Includes material © State of Queensland 2020. You are responsible for ensuring that the map is suitable for your purposes. The State of Queensland makes no representation or warranties in relation to the map contents and disclaims all liability.

Imagery includes material © CNES reproduced under license from Airbus DS. All rights reserved © ZIAT © Earth-4, all rights reserved, 2019

24°52'10"S 151°17'E

24°52'10"S 151°17'E



DRAWING TITLE_ ELEVATIONS SHIPPING CONTAINERS
DRAWING NO_ E_4100/20
DATE_ 3/12/20

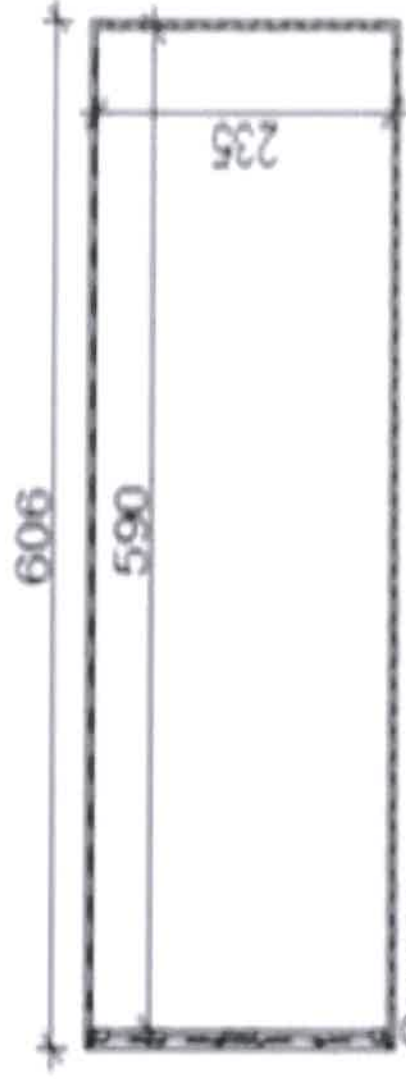

OCHOBA

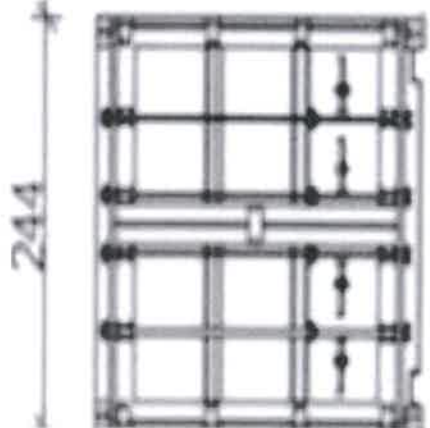
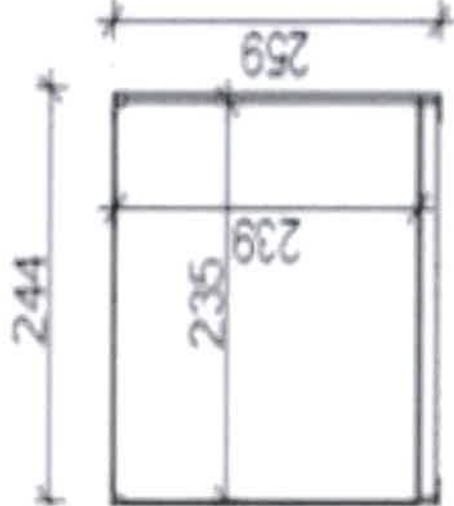
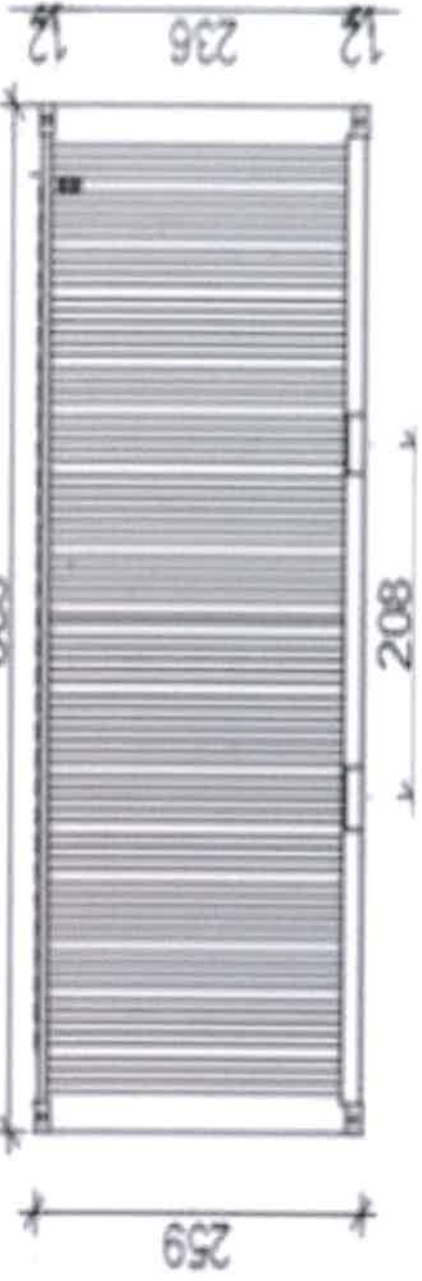

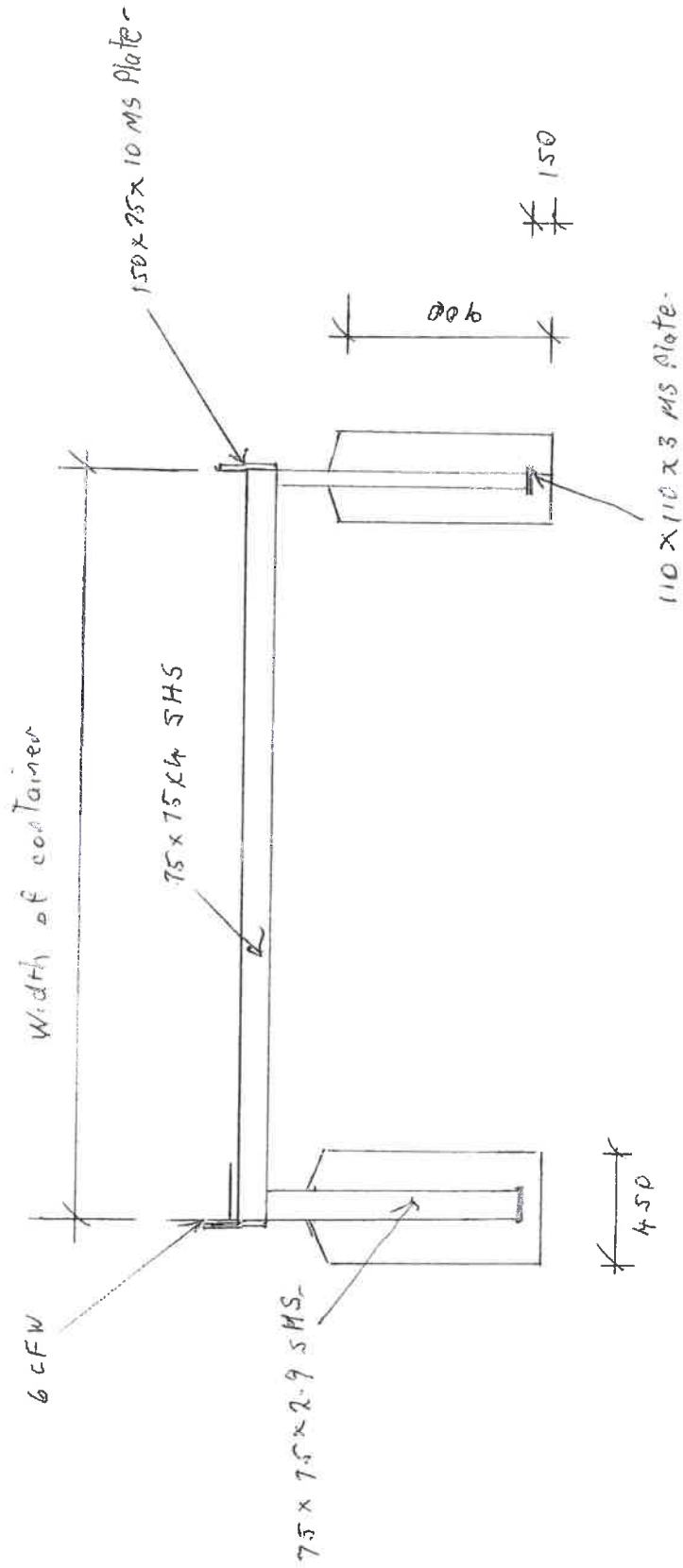

Tie Down at Max 6M Centres